

**TECHNICAL RIDER AND SPECS**  
**FLY ! SUPERFLY !**  
*LAURENT DE WILDE - OTISTO 23 - NICO TICOT*

**Contact for Sound**

Dume (aka OTISTO23)  
+ 33 (0)6 61 19 33 20  
E-mail : [dumedtc@gmail.com](mailto:dumedtc@gmail.com)

**Booking**

ACCES - Olivier CASAYS  
10, rue Sénard  
76000 ROUEN France  
Tél : +33(0)2 35 88 75 74  
Fax : +33(0)2 35 89 20 33  
E-mail : [o.casays@accesconcert.com](mailto:o.casays@accesconcert.com)  
[www.accesconcert.com](http://www.accesconcert.com)



A copy of this document must be signed and returned along with the contract.

Our team is made of 2 musicians and 1 V-Jay :

<b>Laurent de Wilde (piano)</b>	on stage (stage left)
<b>Otisto23 (computer)</b>	on stage (stage right)
<b>Nico Ticot (vidéo)</b>	control booth (next to the light engineer)

## **NEEDED PERSONNEL**

One person to welcome and accompany the artists until their departure.  
One person backstage to secure personal belongings during the show.  
Upon the arrival of our stage manager, during the setup and the show :

- 1 local stage manager
- 1 light engineer
- 1 scene shifter
- 1 sound engineer
- 1 catering and backstage manager

## **SPECS, BACKLINE & MISCELLANEOUS**

- 1 Piano « Steinway & sons » TYPE B. THE TOP HAS TO BE REMOVED  
(a tuning will be necessary before our arrival and just before the show)
- 1 adjustable piano bench
- 1 60x60, height: 80 cm small stand by the piano for Laurent's equipment
- 2 NEUMANN KM84/184 microphones
- 1 Shure SM57 microphone
- 1 Shure Beta52 microphone
- 4 DI Box
- 1 Flat 22 inches minimum (HDMI) computer screen
- 2 20 feet headphone extension cord
- 3 tall microphone stands
- 1 small microphone stand
- 1 adjustable stand 120 x 80 height:100 cm for Otisto's machines.
- 1 midi/usb 61 notes (minimum) keyboard + RTX stand

## **THANKS FOR NOTING THAT**

- 1- The band has to perform BEHIND the Front Sound System, as much possible in the middle of stage to avoid the larsen effect.
- 2- There is no monitor en stage, both artists using ear monitors.

## **CONTACT FOR SOUND : DOMINIQUE POUTET**

dumedtc@gmail.com  
06 61 19 33 20

## **RIDER**

### **Dressing rooms**

Two dressing rooms will be provided next to the stage. They will be exclusively dedicated to the band, heated and/or ventilated, and will have mirrors, a hanging cabinet, electric plugs, an iron and its table, table and chairs for 3 persons, a sofa one can lay on, a shower with soap and towels, some rest rooms. The dressing rooms must be closed with a key.

The musicians will need : fresh water, sodas (coca-cola, orangina), fruit juices, fruits, coffee and tea, biscuits, nuts, paper towels and a bottle of whisky (Aberlour, Oban, Lagavulin ou Caol Ila).

### **Catering - meals**

3 or 4 complete hot meals 90 minutes before the concert or 30 minutes after in a fine restaurant, at the hotel, close to the venue or at the venue.

4 small still water bottles on stage, along with 2 black or dark blue towels

### **Hôtel**

According to the contract, 3 double bed single rooms in a minimum 3 stars hotel, breakfast included

The hotel must be at a reasonable distance from the venue. Thank you for sending us the specifics of the hotel as well as its location and access plan.

### **Press - Photos**

No press conference, interviews, signings or photo sessions will be organized without the approbation of the band manager.

All requests must be adressed at Helene Lifar

**helene@laurentdewilde.com**

All recordings and broadcasting of the show must be arranged with the band manager. The organizer will be accountable for the respect of this non-recording agreement by anyone attending the concert.

## **SCENOGRAPHY – LIGHT - VIDEO**

We need 2 technicians for the organisation/installation.

### The construction :

- Height : 3 m / Diameter : 4,5 m, with hems (up and down) weighed with fine carbon poles.
- The circular screen will be held by 9 halyards, converging toward a central attachment point (brought by XLR Project).

### The video-projectors :

- The 1st VP (VP1) shall have a minimum power of 5 000 Lumens. It will be positioned in the place / room (control room) and must be able to project images with a width of 4,5m on front stage.
- The second VP (VP2) has to be a wide angle video-projector and shall have a minimum power of 3 000 Lumens. It will be positioned in the center of the installation, with our own system.

The video-projectors can be brought by XLR Project or be provided by the organizer. Please, contact XLR Project directly if you wish to know more about the price of this provision.

### The light :

2 x cutting for the interior of the piano and the adjustable stand.

2 x cutting for a overhead lighting for the musicians.

2 x cutting in  $\frac{3}{4}$  (three-quarter) for a overhead lighting on the heads and the chests of the musicians.

**For further technical informations about the scenography, please contact directly :**

**Nicolas Ticot : 06 13 58 55 04 / [nicolas.ticot@xlrproject.net](mailto:nicolas.ticot@xlrproject.net)**

Fly !  
Technique: plan de scène, vidéo et lumières

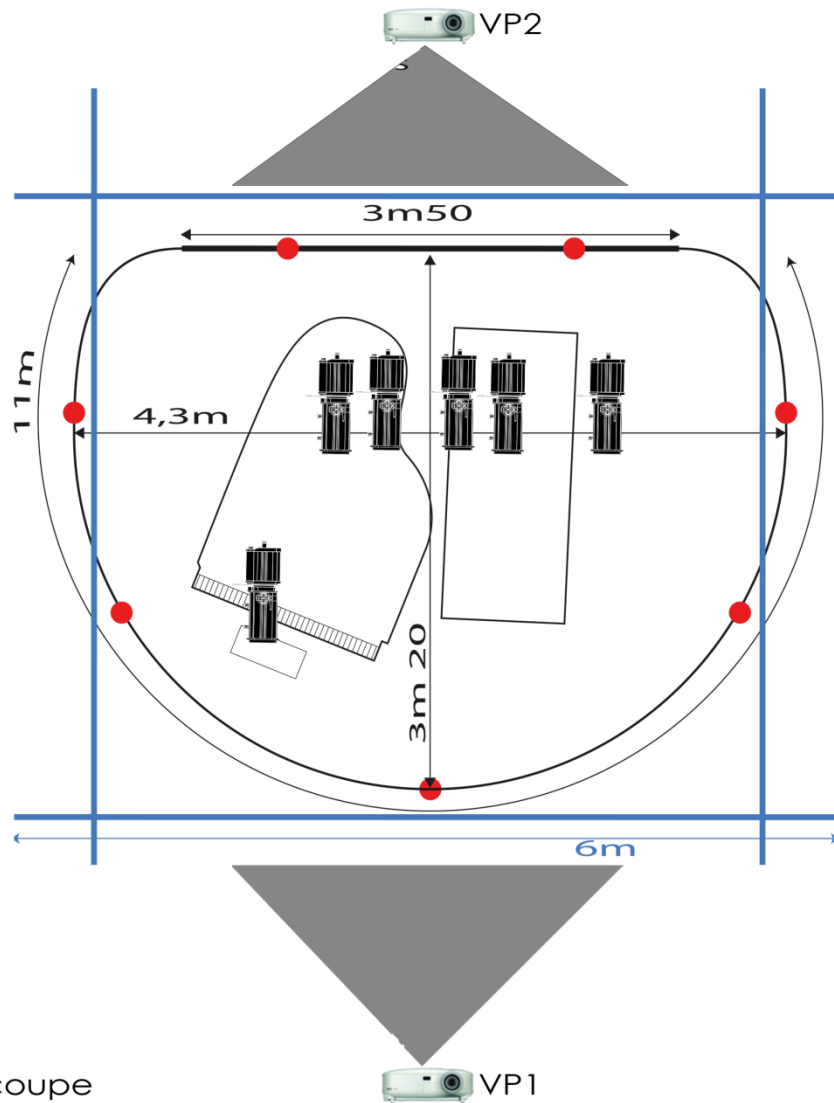

Découpe



VP1 5000 Lmens minimum  
VP2 3000 lumens grand angle



Pont, grille ou barres alu



Point de fixations écran circulaire



Perche de 350 cm